

GROUND AND ARC RAPID DISCONNECT (GARD)

A unique device for detecting ground and arc faults in PV arrays and rapidly disconnecting the impacted PV strings.

INSTALLATION, OPERATION AND MAINTENANCE MANUAL FOR USE WITH THE GARD V2.2

PM006 Revision 7



Alencon Systems LLC

330 Warminster Rd., Suite 380 | Hatboro, PA 19040 | USA

© 2009-2019 by Alencon Systems LLC

This document is the confidential and proprietary information of Alencon Systems LLC. No part of this document may be photocopied, reproduced, stored in a retrieval system, or transmitted in any form or by any means whether electronic, mechanical, or otherwise without prior written permission. Alencon Systems LLC reserves the right to change details in this publication without notice.

Copyright Information: Any product names listed in this manual that are not registered trademarks of Alencon Systems LLC and/or organization names mentioned may be trademarks and/or registered trademarks of their respective companies.

Publication Number: **PM006**

Date and Revision

Revision	ECO	Date	Author	Approval	Comment
0	8569	06/26/2019	Oleg Fishman	PS	Original Manual
1	8570	07/23/2019	Prahalad Shivshankaran	MM	Formatting, content and installation information
2	8571	01/15/2020	Prahalad Shivshankaran	ZD	Adding more relevant information to the manual
3	8572	3/13/2020	Zach Dereli	PS	Changes required for the Certification
4	8573		Zach Dereli	PS	Changes required for the Certification
5	8574	06/19/2020	Zach Dereli	PS	Changes required for the Certification
6	8575	02/01/2022	Prahalad Shivshankaran	PS	Added Arc Detection material into the manual.
7	8576	08/12/2022	Jacob Faber	HF	Updated for GARD V2.2
8	8577	1/18/2023	Jacob Faber	HF	Mounting instructions updated

Table of Contents

1	General Information.....	4
1.1	Purpose	4
1.2	Glossary.....	4
1.3	Product Warranty.....	5
1.4	Technical Support and Assistance.....	6
1.5	Warnings, Cautions and Notes	6
1.6	Packing List	7
1.7	Ordering Information.....	7
2	IMPORTANT SAFETY INSTRUCTIONS.....	8
3	Introduction.....	10
3.1	PV Safety.....	10
3.2	Grounding	10
3.3	Arc Faults.....	11
3.4	Serial arcing.....	11
3.5	Parallel arcing.....	11
4	Detect and Isolate Ground and Arc Faults in Your PV Array	12
4.1	The Ground & Arc Rapid Disconnect Unit (GARD).....	12
4.2	Unique Features & Benefits of the Alencon GARD.....	12
4.3	GARD Specifications	13
4.4	GARD Functionality and Operation.....	14
4.4.1	Functionality	14
4.4.2	Instructions when Ground Fault is Detected.....	14
4.4.3	Instructions when ARC Fault is Detected	15
4.4.4	Principle of Operation.....	15
4.5	GARD Hardware	18
5	Firmware.....	19
5.1	GARD State Machine.....	19
6	Communication.....	21
7	GARD Installation	21
7.1	Understanding GARD Hardware.....	21
7.2	Communication Ports.....	22
7.3	GARD Mounting.....	23
7.4	Cable Terminations.....	25
7.4.1	GARD + SPOT	25
7.4.2	External Fusing and Disconnects	26
8	Interfacing with the GARD	27
8.1	Unit Power	27
8.2	Control System	27
9	Further information	27

Table of Figures

FIGURE 1: THE GARD UNIT	7
FIGURE 2: THE GRAPHIC ABOVE INDICATES THAT THE GARD IS A GROUNDING CONDUCTOR.....	8
FIGURE 3: THE GRAPHIC ABOVE INDICATES THAT THE GARD ACTS AS A DIRECT CURRENT SUPPLY.	8
FIGURE 4: GROUNDING SCHEMES	10
FIGURE 5: ARCING.....	11
FIGURE 6: AFD PCB	16
FIGURE 7: SYSTEM NOISE SIGNATURE DURING AN ARC EVENT.....	17
FIGURE 8 : PV → SPOT → INVERTER SYSTEM NOISE SIGNATURE	17
FIGURE 9: GLID/AFD STATE MACHINE	20
FIGURE 10: EMERGENCY SWITCH	21
FIGURE 11: RESET SWITCH.....	21
FIGURE 12: GARD BOTTOM VIEW.....	22
FIGURE 13: REMOTE E-STOP	23
FIGURE 14: GARD MOUNTED ON UNISTRUT RACKING.....	24
FIGURE 15: AMPHENOL TERMINATIONS ON GARD	25
FIGURE 16: GARD TO SPOT CONNECTOR.....	26

1 General Information

All efforts have been made to ensure the accuracy of material provided in this document at the time of release. Items are subject to continuous development and improvements. All specifications and descriptions are subject to change without notice.

1.1 Purpose

This manual provides information about installing, operating, maintaining, and troubleshooting the Alencon’s **Ground Rapid Disconnect** Unit.

Who Should Read this Manual?

This manual should be read by anyone who needs to:

- Understand the product
- Plan the installation
- Install the product
- Commission the product
- Operate the product
- Maintain the product,

1.2 Glossary

Word(s)/Acronyms	Definition
GARD	Ground Rapid Disconnect
BOSS	Bi-directional Optimizer for Storage Systems
SPOT	String Power Optimizer and Transmitter
ACE	Alencon Communication Environment – a communication system containing hardware and software elements provided by Alencon to control power conversion equipment
PODD Site / HUB	Alencon Communication, Monitoring and Control Software
AFD	Arc Fault Detector

1.3 Product Warranty

Alencon Systems warrants to you, the original purchaser, that each of its products will be free from defects in materials and workmanship for three years from the date of purchase. Extended warranty of up to 10 years are also available for purchase.

This warranty does not apply to any products which have been repaired or altered by persons other than repair personnel authorized by Alencon System, or which have been subject to misuse, abuse, accident or improper installation. This warranty does not cover the repair or replacement of any goods which fail as a result of damage in transit, misuse, neglect, accident, Act of God, abuse, improper handling, misapplication, modification, improper storage, excessive stress, faulty or improper installation, testing or repair, negligent maintenance or failure to comply with the written instructions for installation, testing, use or maintenance (if any) provided by Alencon Systems. Alencon Systems assumes no liability under the terms of this warranty as a consequence of such events.



Because of Alencon Systems' high quality-control standards and rigorous testing, most of our customers never need to use our warranty service. If an Alencon Systems product is defective, it will be repaired or replaced at no charge during the warranty period. For out-of-warranty repairs, you will be billed according to the cost of replacement materials, service time and freight. Please consult Alencon Systems for more details. If you think you have a defective product, follow these steps:

1. Collect all the information about the problem encountered. (For example, issues you are encountering in your PV array or battery system) Note anything abnormal when the problem occurs.
2. Call Alencon Systems or your licensed Alencon Systems dealer and describe the problem. Please have your manual, product, and any helpful information readily available.
3. If your product is diagnosed as defective, obtain an RMA (return merchandise authorization) number from your Alencon Systems. This allows us to process your return more quickly.
4. Carefully pack the defective product (preferably in the original packaging material it was shipped in), a fully-completed Repair and Replacement Order Card and a photocopy proof of purchase date (such as your sales receipt) in a shippable container. A product returned without proof of the purchase date is not eligible for warranty service.
5. Write the RMA number

1.4 Technical Support and Assistance

1. Visit the Alencon Systems web site at www.alenconsystems.com where you can find the latest information about the product.
2. Contact your distributor, sales representative, or Alencon Systems' customer service center for technical support if you need additional assistance. Please have the following information ready before you call:
 - Product name, LIN and serial number (see section 6.5 for more information the location of the LIN and serial number)
 - Description of your peripheral attachments including fusing and cables

1.5 Warnings, Cautions and Notes

	Warning!	<i>Warnings indicate conditions, which if not observed, can cause personal injury!</i>
	Caution!	<i>Cautions are included to help you avoid damaging hardware or losing data.</i>
	Note!	<i>Notes provide optional additional information.</i>

1.6 Packing List

Before installation, please ensure the following items have been shipped:

- Correct # of GARD Units specified for your plant with appropriate mounting hardware



Figure 1: The GARD Unit

1.7 Ordering Information

Model Number Description

Model Number	Description
<i>GARD-1000-V2.2</i>	Ground Rapid Disconnect Unit. 4 INPUT/OUTPUT

2 IMPORTANT SAFETY INSTRUCTIONS



WARNING!

SAVE THESE INSTRUCTIONS– This manual contains important instructions for use with the GARD that shall be followed during installation and maintenance of these devices.



Figure 2: The graphic above indicates that the GARD is a grounding conductor.



Figure 3: The graphic above indicates that the GARD acts as a direct current supply.



Installation of this equipment must be performed by an authorized electrician in accordance with the local and NEC ANSI/NFPA 70 and OSHA requirements. Installation shall be in accordance with the Canadian Electrical Code, Part I when installed in Canada.

1. Before installing and using the GARD, read all instructions presented in this manual and the cautionary markings shown on the GARD's enclosure.
2. The GARD contains no user-serviceable parts. For service and maintenance, the GARD should be returned to Alencon Systems LLC or a certified Alencon Systems service center.
3. During operation, hazardous voltages and currents may be present. Only authorized and qualified personnel should perform servicing/installation.
4. The metallic enclosure surface may become hot during certain operation circumstances.
5. Exposed PV strings to sunlight represent a shock hazard at the PV wires and exposed terminals. Cover the PV modules with dark material when performing the installation in order to reduce the risk of shock during the process. Test any wire or terminal for the voltage before touching them.
6. Use only accessories recommended or approved by the manufacturer.

7. Ensure that wiring is in good conditions and that all wiring is sized accordingly. Ignoring to do so may result in a risk of fire.
8. PV modules produce electrical energy when exposed to light and thus can create an electrical shock hazard. Wiring of the PV modules should only be performed by qualified personnel.
9. Always have GARD manual in hand.



WARNING! GARD is NOT a field serviceable product. Please contact Alencon Systems for any issues with the product.

3 Introduction

3.1 PV Safety

As with any electrical appliance, solar panels can be at risk to certain electrical damages and dangers, such as solar panel fires and power surges. Luckily, there are plenty of measures in place to ensure safe PV operation. This document provides a brief on the safety issues often seen on PV systems and Alencon’s preventive approach to safe operation through the Ground & Arc Rapid Disconnect unit – the GARD.

3.2 Grounding

All bodies including equipment frames and people in contact with Earth are charged to Earth (ground) potential. Therefore, touching grounded equipment frames is safe.

Electrical sources like solar panels or electrical batteries generate voltage or difference of electrical potentials between two terminals. When the terminals are connected to a conductive load, the current begins to flow from the source to the load thereby generating power.

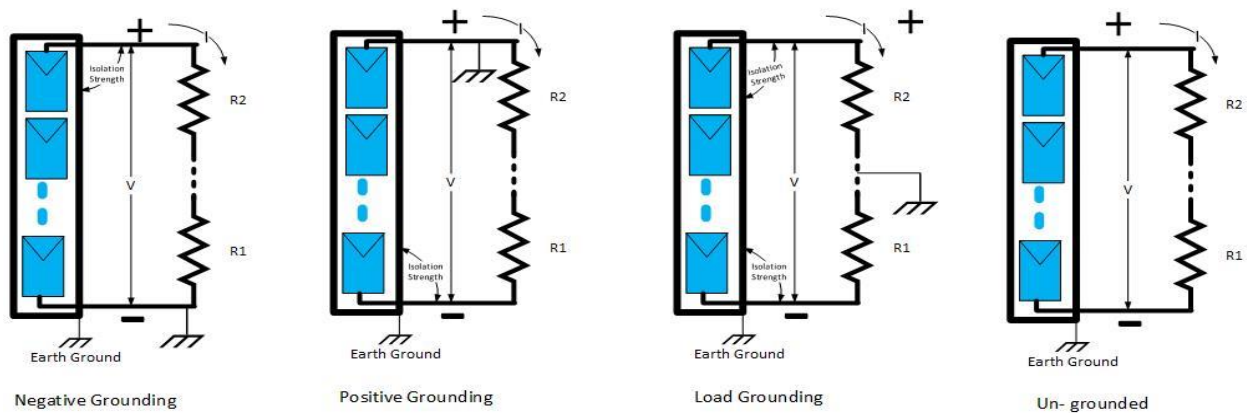

Figure 4: Grounding schemes

A ground fault is an inadvertent contact between an energized conductor and ground or equipment frame, thereby providing an alternative pathway for the current to “**leak**” to ground. The return path of the fault current is through the grounding system and any personnel or equipment that becomes part of that system. Ground faults are frequently the result of insulation breakdown - damp, wet, and dusty environments expose the grounding system to degradation of insulation and increase the potential for hazards to develop.

The common grounding schemes found in a PV system are –

- Negatively Grounded PV
- Positively Grounded PV
- Ungrounded/Floating System

Either the positive or negative terminal of the source/load system can be connected to ground potential. In this case the voltage on the second source terminal is referenced to ground or to the equipment frame and defines the break down insulation strength.

Alternatively, any point on the load can be grounded, establishing the positive and negative potentials to ground. Finally, no point in an electrical system is grounded. In this case the positive and negative potentials are undefined and considered “floating”. *This network is used in very sensitive applications like, for example, high voltage Lithium Ion batteries where ground leak current can result in an explosion.*

Alencon’s GARD is designed to detect leakage currents for grounded systems as shown in Figure 4 by measuring the current difference in positive and negative terminals. Thus, the GARD is UL listed to detect grounds faults in either positively or negatively grounded systems. The GARD, by default, will negatively ground the system in front of the SPOT. Should you wish to positively ground the system, this should be indicated prior to order. As the GARD is designed for use with the SPOT, the grounding of the PV array will appear as floating on the output of the SPOT since the SPOT is galvanically isolated.

3.3 Arc Faults

PV systems are subject to arcing of electrical wires. There are two types of arc faults that can occur in a PV system:

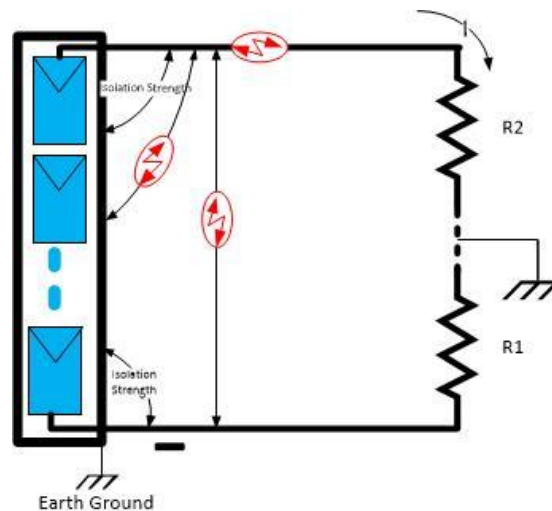

Figure 5: Arcing

3.4 Serial arcing

This type of arcing happens inside the wire, when a conductor is broken but the insulation is still intact. In such cases, the wire is still intermittently conducting through the arc. Serial arcs produce extreme local heat and can cause wire insulation to catch fire. ***The GARD has been designed to detect serial arcing only.***

3.5 Parallel arcing

This type of arcing happens between a wire and exposed ground potential when the wire insulation is compromised. Alternatively, the arc can strike between positive and negative wires if insulation on both is damaged. The GARD has not been designed to detect parallel arcing.

4 Detect and Isolate Ground and Arc Faults in Your PV Array

4.1 The Ground & Arc Rapid Disconnect Unit (GARD)

Alencon's **G**round and **R**apid **D**isconnect unit, the **GARD**, is a unique solution for detecting harmful ground and arc faults in your PV array at the string level. When detecting these faults, the GARD automatically disconnects the faulty string. The GARD communicates with the customer's SCADA system via a *MODBUS RTU* communication link.

The GARD also offers the ability to rapidly and safely disconnect PV strings with either a local or global E-STOP switch or via remote MODBUS commands. The GARD can be deployed as a standalone device or in conjunction with Alencon's String Power Optimizer and Transmitter – the SPOT. Additionally, it can be used with or without remote communications.

The GARD can be installed in new PV systems or as a retrofit to existing solar plants.

4.2 Unique Features & Benefits of the Alencon GARD

- Detect and isolate potentially dangerous ground leakages and arc flashes at the string level
- Quickly turn off faulted strings
- Reduce O&M costs by determining precisely where faults are occurring in a PV array
- Maintain power production during maintenance by not having to shut down entire combiners or arrays when repairing electrical faults
- Remote Control via an external E-STOP and Modbus Commands

4.3 GARD Specifications

Overall Device Capabilities	
Fault Detection and Interruption	Combined Ground and ARC fault detector and interrupter/disconnect for PV strings
Max Voltage Rating Per Input (Voc)	1000 VDC
Operating Voltage Range	200 – 1000 VDC
Max Current Rating Per Input	25A
Short Circuit Current Per Input (Isc)	30A
Number of Individual Inputs	4
Communication	Modbus TCP via Alencon Communications Environment (ACE)
Fault Detection and Disconnect Level	Faults are detected per input, i.e. PV string level
Fault Latch	Yes
Disconnect	Yes
Reset	Yes
Fault/Status indicators	Yes
Ground Fault Detector Capabilities	
Common grounding	Negative / Positive
Ground fault current trip levels	Configurable from 500 mA to 1 A
Overvoltage Class	OV II
ARC Fault Detector Capabilities	
Insulation	> 3000V
Self Input Test	Yes
ARC Detect Output	Yes
Photovoltaic DC Arc – Fault Circuit – Protection	Type 1
Power Supply	
Internal On Board	+24 V
Indicators	
Power ON	Red LED
Channel status (4)	Green – Relays Closed Red – Relays disconnected
Controls	
Stop	Local E-STOP, Global E-STOP, Modbus command
Reset	Local Reset, Modbus command
Standards & Compliance	
Certifications	UL1741, CSA C22.2#107.1 (Ground Fault), UL1699B (Arc Fault)
Environmental	
Storage Temperature	-40°C to 60°C
Environmental Rating	NEMA 3R & IP 36
Cooling	Convection
Humidity	0 – 95 %
Operating Ambient Temp.	-30°C to 50°C
Pollution Degree	PD III
Physical Characteristics	
Size (H x W x D)	.46 M x .37 M x .17 M
Weight	10.5 kg

4.4 GARD Functionality and Operation

4.4.1 Functionality

The SPOT or any upstream equipment is connected to the PV System via the GARD. The communication with GFDI/AFD is carried out via MODBUS.

The GFDI provide ground and arc fault protection features to the existing SPOTs. The GARD generates its own control voltages. A microcontroller monitors the currents and voltages in all four PV channels and controls and monitors the AFD module. Self-tests on the GFDI and AFD are performed automatically every day.

In the event of a fault, the faulty channel is disconnected preventing ground leakages and arc flashes on the commensurate input PV wires. Local indicators report the status of the GARD. A remote monitoring facility is available via MODBUS. The operator can enforce the disconnection manually by using an external switch (E-STOP) or remotely by sending MODBUS commands. After the system is safely shutdown and the fault cleared, the GARD can be manually reset using the reset push button available locally on the GARD or via a Modbus Reset command.

4.4.2 Instructions when Ground Fault is Detected

In the event of a ground fault, the faulty channel is disconnected preventing ground currents from flowing. Local indicators report the status of the GARD. A remote monitoring facility is available via MODBUS. Follow the suggested actions below;

1. When a ground fault is indicated the corresponding channel will trip and indicate a ground fault. The ground current will be interrupted by the GARD. When the unit is tripped the LED for the tripped channel on the GARD will turn RED. The status of the GARD can be monitored on the HUB user interface. Refer to the HUB manual for more information.
2. When a ground fault is indicated normally grounded conductors may be ungrounded and energized or normally ungrounded conductors may be grounded.
3. The ground fault will be on the channel that tripped due to ground fault.
4. Press E-Stop button to disconnect all other channels.
5. Check the input and output wires of the tripped channel to make sure there is no current flowing.
6. After ensuring that there is no current flowing through the tripped GARD channel, disconnect the input and the output wires.
7. Once the tripped channel is safely disconnected, reset the GARD by disengaging the E-STOP button and pushing the Reset switch. The GARD can also be reset using the HUB user interface.
8. Disconnected PV strings must be inspected by the authorized maintenance personnel.
9. Once the faulty string(s) are restored they can be reconnected back to the GARD channel.

4.4.3 Instructions when ARC Fault is Detected

In the event of an arc fault, the faulty channel is disconnected and isolated preventing arc flashes. Local indicators report the status of the GARD. A remote monitoring facility is available via MODBUS. Follow the suggested actions below;

1. When an arc fault is detected all channels will be disconnected with the GARD status indicators OFF and the status telemetry reading "ARC Fault Detected".
2. After an arcing even, the GARD transitions to the "self-test" state and sequentially cycles power through individual channels A,B,C & D for 150 seconds each.
 - a. During the 150 seconds, if an arc is detected, the channel is disconnected and a flag is raised on the Alencon HMI.
3. Faulted channels will be disconnected with the status indicators glowing RED while unfaulted channels will be re-energized with indicators glowing green.
4. Alencon HMI will update the status and indicate faulted channels to the user.
5. If servicing is to be completed, press the E-Stop button to disconnect all other channels.
6. Check the input and output wires of the tripped channel to make sure there is no current flowing.
7. After ensuring that there is no current flowing through the tripped GARD channel, disconnect the input and the output wires.
8. Once the tripped channel is safely disconnected, reset the GARD by disengaging the E-STOP button and pushing the Reset switch. The GARD can also be reset using the HUB user interface.
9. Disconnected PV strings must be inspected by the authorized maintenance personnel.
10. Once the faulty string(s) are restored they can be reconnected back to the GARD channel.

4.4.4 Principle of Operation

4.4.4.1 Manual Operation

The GARD operates autonomously. The connected input PV strings power up the GARD. The GARD automatically performs a self-test of the GFDI and AFD before transitioning to normal operation i.e. RUN. If no faults are detected, the channel LED's (A, B, C, D) turn GREEN. If a fault is detected on one of the channels, the indicator light on this channel turns RED.

The reason for a fault should be investigated and the fault should be repaired. Once a fault is cleared, the red indicator may be cleared by depressing the RESET pushbutton.

4.4.4.2 Remote Monitoring and Control

The GARD is a very intelligent device. The software controls operating as a State Machine is described in sections below. The states and statuses are communicated via Modbus RTU as described in section 6.

4.4.4.3 GFDI Principle

GFDI monitors the ground leak current in each of the GARD's four channels. The GFDI measures the input current on the PV positive and negative terminals and compares the values. If the current difference exceeds a preset magnitude, the GFDI will disconnect the faulty channel both on the positive and negative terminals. The FAULT flag is recorded into the GARD's non-volatile memory and the channel indicator turns from GREEN to RED. Faults can be cleared only by the operator either by activating the RESET button on the GFDI face plate or by sending a RESET command via MODBUS RTU. GFDI can be configured to detect a ground leak either for negatively grounded, positively grounded or floating PV systems.

4.4.4.4 Arc Detection

The arc fault detector has been designed to work in conjunction with Alencon's ground fault detector and interrupter. The board has been designed and developed to detect an arc and provide an interrupting signal to the ground fault PCB. If an ARC signal is generated by the detector, the GARD relays turn-off interrupting the current, thereby disconnecting the string.



Figure 6: AFD PCB

Arc fault detection is based on the arc noise signature analysis. The noise floor spectrum is not a fixed waveform but a function of the power electronic equipment in-line, the operating conditions and current transients. Detection schemes must be capable of handling the various peaks without false tripping.

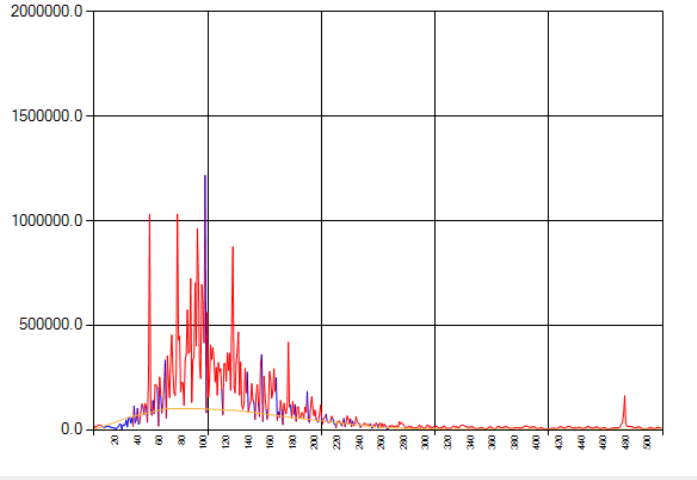

Figure 7: System noise signature during an arc event

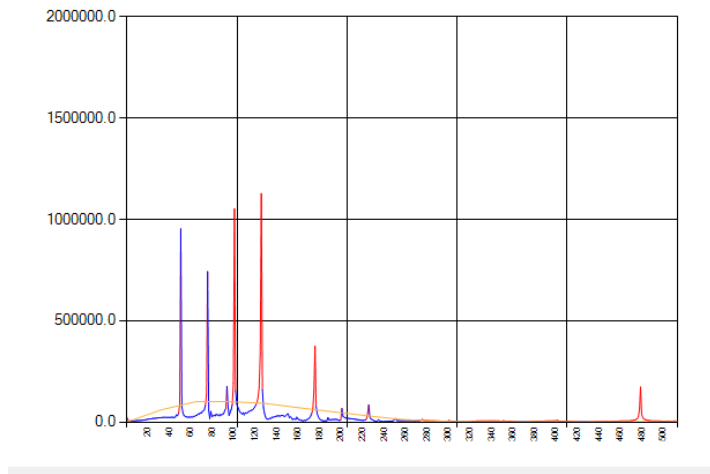

Figure 8 : PV → SPOT → Inverter system noise signature

During the operation of a PV system, the noise floor fluctuates depending on operating conditions, transient's etc. Alencon's AFD is constantly monitoring the noise floor for deviations in spectrum magnitude. During a sustained arc event, the system noise signature rises in magnitude. The differential change in magnitude is observed, recorded and displayed and a signal is sent to the microprocessor to throw an arc fault flag.

4.5 GARD Hardware

Internally, the GARD is implemented as a single PCB motherboard and one daughter PCB. The motherboard provides the following functions:

- Controls
- Ground Leak/Fault Detection
- Arc Detection Board
- PV Disconnect upon fault
- Channel Status

The Motherboard houses:

- Auxiliary Power Supply
- 8 DC Current Sensors: 2 per channel
- 8 High Voltage Relays: 2 per channel
- Microprocessor Controls
- Self-Test, Pre-\Circuits
- AFD Sensor

5 Firmware

All of the GARD's control tasks are executed by the firmware stored in the microcomputer memory mounted on the GARD's main PCB. The program is constructed as a "**State Machine**".

5.1 GARD State Machine

The GARD's "**State Machine**" contains seven main states. The control transition from state to state is shown in Figure 9.

- **INITIALIZE:** Upon power up, or receiving a SHUTDOWN, RESET, CLEAR_FLAGS or TESTMODE command, the GLID/AFD enters the INITIALIZE state. In the INITIALIZE state, the MCU resets and checks for the fault flags. If the flags SHUTDOWN or TESTMODE are not set, the microprocessor proceeds into the STANDBY state.
- **STANDBY:** In the STANDBY state, the microprocessor checks that the control voltages and all the sensors are in operating range and then proceeds into a SELF-TEST state.
- **SELF-TEST:** In the SELF-TEST state, the microprocessor performs a set of self-tests that essentially check the quality of the GARD sensors i.e. current sensor.

CT Check – GARD injects a current into the circuit that flows through the negative current sensor. This difference should simulate a current fault. If any of the channels fail to detect the "**simulated fault**" they will be disconnected and a fault flag will be recorded in the GARD's non-volatile memory (NVM). If at least one channel is found to be good the microprocessor proceeds into PRECHARGE state for that commensurate channel.

AFD_self_test – A sample arc signature is generated during self-test and the AFD board reacts to the sample signature and a flag is generated. This is a self-evaluation that must pass prior to the relays closing.

- **PRECHARGE:** In the PRECHARGE state, the GARD pre-charges the capacitors available on the output for a dedicated time period defined by the configuration file. In this state, the relays on the negative terminal are closed, while the open contacts are bypassed by a "soft-start" resistor. This feature preserves the life of relay contacts. Once the load capacitors are charged, the relay on the positive terminal is closed. When the PRECHARGE process is complete on all four channels the microprocessor proceeds into RUN state.
- **RUN:** The RUN state is the main state of the GLID/AFD. In RUN state the microcontroller is looking for a ground leak fault.
- **Ground leak:** The leak-locator hardware on the board helps identifying groundfault before the relay contacts close.

- **SHUTDOWN:** The GLID/AFD stays in the SHUTDOWN state and keeps all relays de-energized as long the SHUTDOWN flag is set.
- **TESTMODE:** Upon receiving the TESTMODE command, the GARD/AFD is initialized and initially set into SHUTDOWN state. While in TESTMODE, the user has access to the MODBUS registers and can transfer the GLID/AFD into STANDBY, PRECHARGE, RUN states.

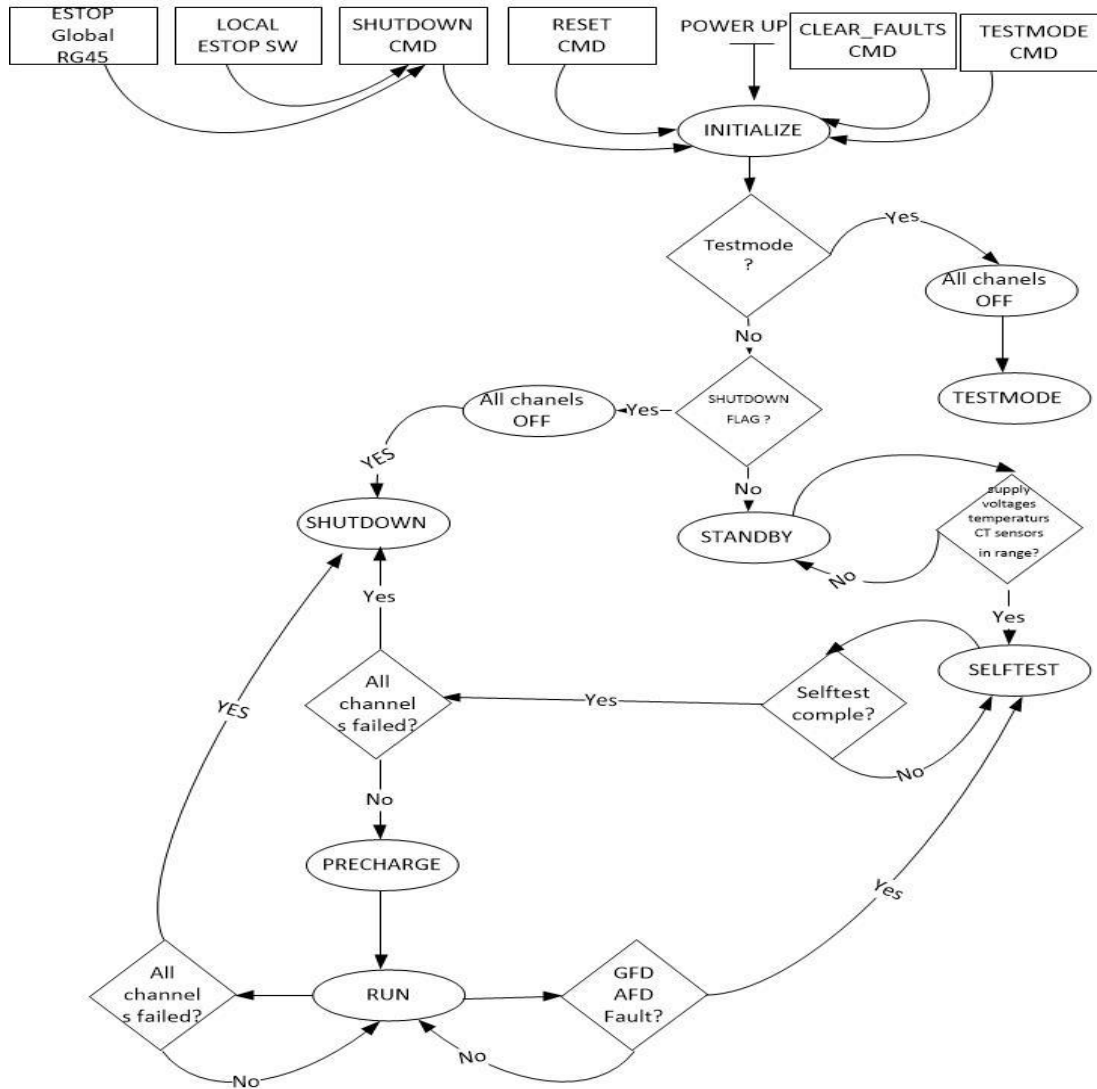

Figure 9: GLID/AFD state machine

6 Communication

The communication with the GARD is carried out via ModbusTCP/IP through the Alencon PODD device. The Modbus Map will be provided to you upon request.

7 GARD Installation

7.1 Understanding GARD Hardware

The GARD's global status and channel statuses are indicated by LED's on the face of the GARD: A Red light indicates that the channel is disconnected either due to a fault or a command while Green light indicates that the channel is connected and running.

- **Emergency Switch** – The emergency switch is a push button that provides power to the relays. The switch has been configured to operate in the NC position, providing 24 V power to the internal relays. If an operator wants to turn-off (OPEN) the relays safely on the field, they would have to push the button in towards the GARD. This will put the switch in the NO position, disconnecting the power to the relays. To disengage the emergency switch, twist and pull the knob away from the GARD, towards the operator.



Figure 10: Emergency Switch

- **Reset Switch** – This switch has been provided so the operator can forcefully reset the GARD either after the occurrence of a fault or the clearance of the fault. The push button provides a hard reset which will clear all flags and faults and force the GARD into the standby state.



**Figure 11:
Reset Switch**

Note: The reset button will only work after the emergency switch has operated.

- **Channel LED's** – The channel LED's have a binary operation i.e. they are illuminated Green if channel is in RUN mode and Red if it is in shutdown
- **Status LED** – The status LED is illuminated as soon as the PV voltage is applied to the GARD. It is an indicator that remains RED throughout the operation of the GARD. The illumination is an indication that the GARD controls are active and ready for operation.

7.2 Communication Ports

With the help of two weather proof RJ-45 connectors, a number of GARDs may be daisy chained and connected to SCADA controller or to the ACE (Alencon Communication Environment network). Through the same RJ45 connector all the GARDs in the network are wired to a global E-STOP that can remotely disable the GARD i.e. disconnect/isolate PV strings from the Output.

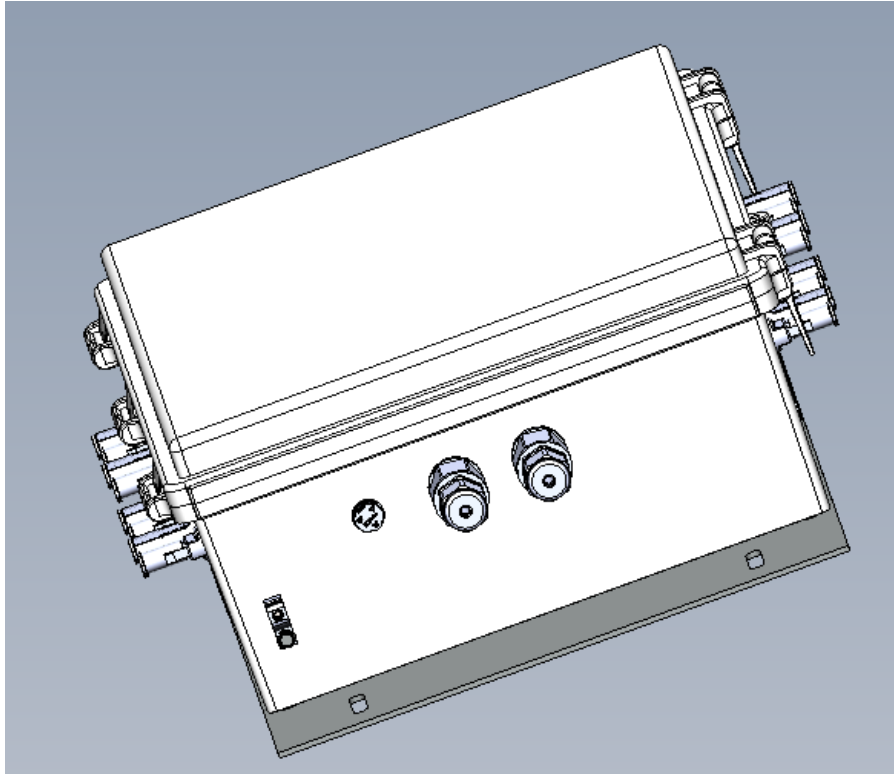

Figure 12: GARD Bottom view

The GARD offers a remote disconnect feature i.e. Remote-E-Stop that can be used in emergency situations. We can turn_OFF the relay operation and disconnect the PV strings remotely if required. The GARD uses the same RJ45 communication channel to do this. Below picture explains how this works –

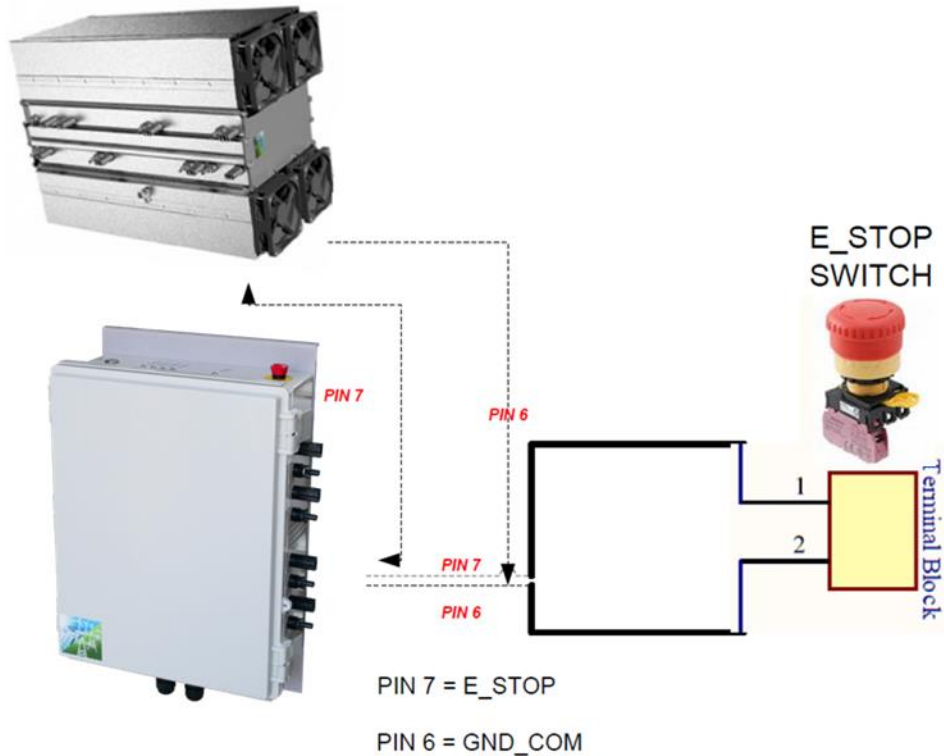

Figure 13: Remote E-STOP

The Switch is configured to operate in the NC operation (default).

7.3 GARD Mounting

The GARD can be easily mounted using standard Unistrut® along with spring loaded channel nuts. The GARD comes with a hooked backplate that allows for the GARD to be hung on the Unistrut and then fastened using a Hex head screw. Recommended hardware for mounting is as follows:

- Unistrut® – Any typical zinc plated or galvanized steel Unistrut
- Strut Channel Nuts with Spring, 13/16" Channel High, 5/16-18 Thread – x2 per GARD
- Hex Head Screw, Grade 8 Steel, 5/16"-18 Thread Size, 1" Long – x2 per GARD

To properly hang the SPOT onto a Unistrut:

- 1) Ensure you have a strong base to mount the GARD as seen in the image below.
- 2) Ensure H4 connectors and RJ-45 connector ports are free from stress. Do not hold by any of these points when lifting.
- 3) Lift the GARD until the hooked mounting plate lines up with the Unistrut.
- 4) Once everything is lined up you are ready to hook the GARD in place as seen below
- 5) Once GARD is secured in place, fasten the bottom end of the mounting bracket to the Unistrut using 5/16th Hex Head Screws

No cooling is required for the GARD. When mounting the GARD;

1. Have at least 2 feet of clearance from the ground. Installing the GARD at chest height is recommended for easy operation and to protect the unit from environmental factors such as water and snow.
2. At least 18 inches of clearance is recommended from the sides for easy connection of the power cables.

NOTE: Installation of this equipment must be performed by an authorized electrician in accordance with the local and NEC ANSI/NFPA 70 and OSHA requirements. Installation shall be in accordance with the Canadian Electrical Code, Part I when installed in Canada.



Figure 14: GARD mounted on Unistrut racking

7.4 Cable Terminations

The GARD can either be used as a standalone product in a PV system or coupled with Alencon's optimizer product - the SPOT.



Figure 15: Amphenol Terminations on GARD

7.4.1 GARD + SPOT

If the PV system is already fitted with SPOT's, you must be pay attention to the physical connectors that go from the GARD to the SPOT.

To break it down, the list below explains how input/output connections should be for a GARD + SPOT system:

- Input of GARD = PV
- Output of GARD = Input of SPOT
- Output of SPOT = Combiner BOX/Inverter/Load

Prepare appropriately Sized Wires so that on both GARD Input and Output:

- +ve Terminal = Female Amphenol Pin
- -ve Terminal = Male Amphenol Pin

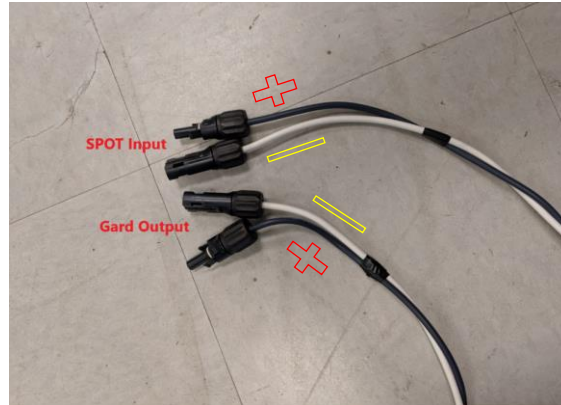

Figure 16: GARD to SPOT connector

7.4.2 External Fusing and Disconnects

GARD acts as a disconnect between its input and output terminals, therefore it is also used to de-energize the PCS or other power conversion equipments connected to its output terminals. External disconnects are not required however the PV strings must be fused in order to comply with the NEC code.

- Recommended external fuse rating per channel is $I_{sc} \times 1.25$ at 1000 VDC
- When installed, recommended disconnect rating is $I_{sc} \times 1.25$ at 1000 VDC

GARD is built to work with a PV string which has a limited source of current. When used with batteries which can deliver high currents external overcurrent protections such as fuses and disconnects must be connected to the GARD.

8 Interfacing with the GARD

8.1 Unit Power

To power ON the GARD, apply $\geq 200V$ to the GARD Input.

The unit is powered directly from the PV strings, which means that the operation is not possible until at least one of the strings is capable of providing 200V. All relays, which connect to the outputs, are de-energized, when the unit is off.

As soon as you power the GARD, you can access the HUB using the PODD. The two files necessary to ensure communication with the board is –

- *metadata File*
- *Hub_Config File*

Both these files would be pre-loaded onto the PODD or be provided to you by Alencon via secure file transfer. Once the PODD is setup, applying minimum voltage or external 24 V will turn ON the GARD boards, allowing two way communications with the HUB.

8.2 Control System

All protection tasks, controls and communication are handled by the microcontroller. The controller monitors all currents and voltages, monitors and control the AFD, control relays, communicates with SCADA and controls individual inputs and output indicators.

The GARD is an autonomous protective device that requires very minimum human intervention to operate. It can be configured to startup as soon as auxillary power is provided. Once power is available, it will complete a series of self-tests before closing the relay contacts.

9 Further information

For more information on DC-Coupled products and solutions, please visit <https://alenconsystems.com/>

Contact us @ <https://alenconsystems.com/alencon-and-you/>

For technical support please email: support@alenconsystems.com or call +1 (215) 816-3366